

# Steam Warm-up Valves

## >> Steam Best Practices

Sheet 9

### 1. IMPORTANCE OF A STEAM WARM-UP VALVE

A steam warm-up is an essential part of the steam system because it helps ensure a safe and reliable operation. The starting up or warming up of a steam system is when the highest condensation and all the thermal expansion of the steam line occurs. Therefore, to optimize safety and reliability, the steam line must be warmed up in a predetermined time frame, with a slow ramp up to the desired temperature and pressure.

### 2. WHAT IS A WARM-UP VALVE?

A warm-up valve is a small valve installed in a piped or tubing bypass loop configuration around a large isolation valve or installed in a pressure-reducing valve (PRV) station. Some other special applications require a warm-up valve, but they will not be covered in this best practice.

At start-up, the warm-up (smaller) valve is opened before the larger valve (isolation or PRV valves) are opened to allow the system to warm up gradually and to equalize pressure on both sides of the isolation valves. The equalized pressure enables an easy opening of the larger valves, reduces thermal shock, and eliminates other problems associated with trying to open larger valves with high-pressure differentials, such as water hammer, wire drawing, or erosion.

Steam systems typically use a gate valve for isolation, and the design of a gate valve requires equal or close to equal pressure on both sides of the internal gate for the valve to open without external force. If the pressure is not equalized, then an external force, such as a pipe wrench or a cheater bar (the nickname for devices that open gate valves), must be used to open the valve handle. See Figure 1. Using this type of force on a gate valve is an unsafe practice that can lead to injury or death.



*Figure 1: Cheater Bar*

As shown in Figure 2, a gate valve will have a force on the P1 (inlet) side that will put extreme force on the gate, thrusting it into the valve seating surface. Using a warm-up valve, the P2 (outlet) pressure will counter the P1 force, and the gate will be allowed to rise without using external forces.

If the plant operation is using a butterfly or ball valve, which are quarter-turn valves, for steam isolation applications, then warm-up valves are essential to bring the system up to pressure. It is impossible to warm up a steam system slowly with the use of a butterfly valve or ball valve that is 3" or larger.

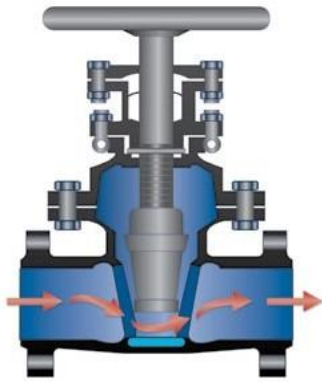

*Figure 2: Using a Warm-Up Valve with a Gate Valve*

### 3. WHAT SIZE STEAM LINE REQUIRES A WARM-UP VALVE?

When installing an isolation, shutoff, or bypass valve on the steam distribution system (**3" or larger**), it is necessary to install a small valve ( $\frac{1}{2}$ ",  $\frac{3}{4}$ ", or 1") around the isolation valve. What size the warm-up valve should be depends on the length and diameter of the steam line that needs to be warmed up.

### 4. REQUIREMENTS FOR WARM-UP VALVES

All warm-up valves should be selected for the following characteristics:

1. The needle valve design is preferred for throttling steam.
2. The globe valve is the second choice for internal valve design.
3. The internal permissible leak rate standard should be higher than a Class IV shutoff.
  - American National Standards Institute (ANSI) or FCI standards
  - API standards

4. The outlet piping or tubing needs to be increased by one pipe diameter.
  - Example: With  $\frac{3}{4}$ " inlet piping and a  $\frac{3}{4}$ " warm-up valve, the outlet piping/tubing should be 1" or larger. This will reduce the velocities out of the valve and improve the valve's reliability.
5. Two valves should be installed on the warm-up line:
  - one valve for the warm-up operation, and
  - a second valve for isolation.
    - Double block valve with a bleed valve
    - More than one warm-up valve can be installed
    - For larger steam systems

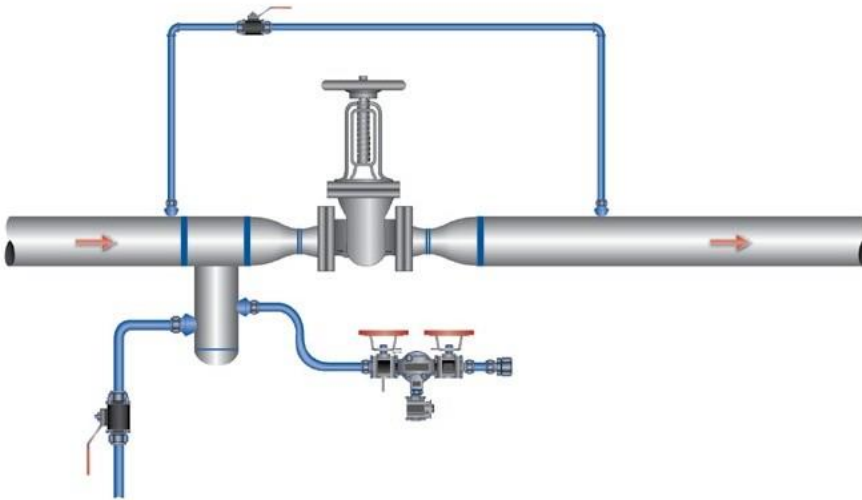

*Figure 3: Isolation Valve with a Warm-Up Loop*

## 5. APPLICATIONS FOR WARM-UP VALVES

### 5.1 Steam Isolation Valves

One of the most common applications is the steam line isolation valve installation.



*Figure 4: Diagram of a Warm-Up Valve Installation*

## 5.2 Single-Stage PRV Stations

The single-stage pressure-reducing valve (PRV) is another application for warm-up valves.

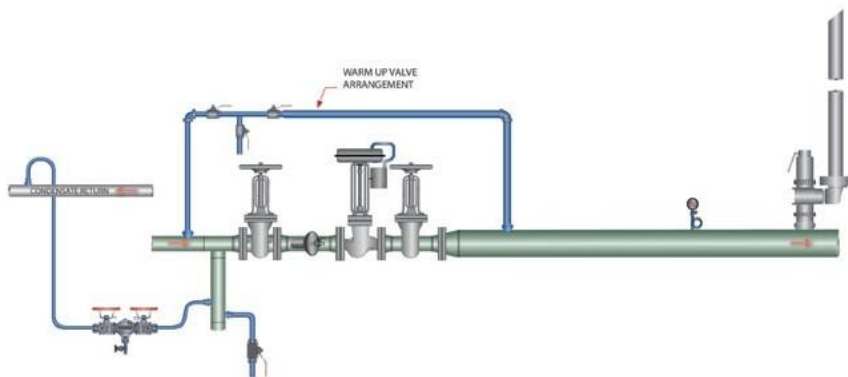

Figure 5: Single-Stage PRV

## 5.3 Two-Stage PRV Stations

The two-stage PRV is an additional application for warm-up valves.

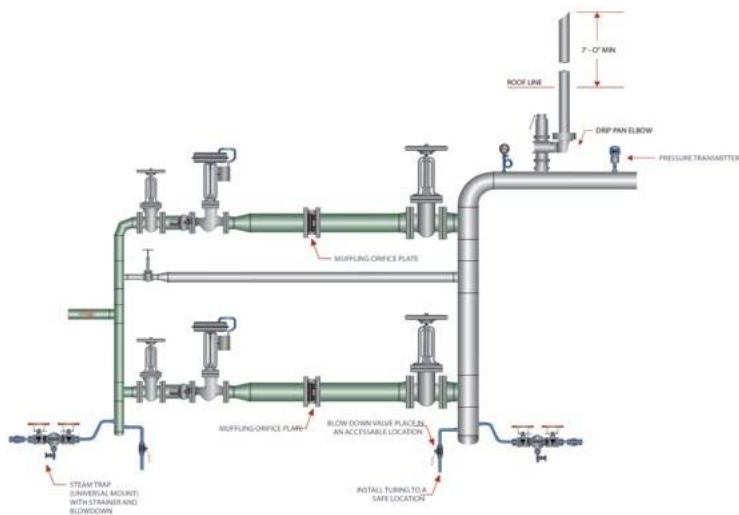

Figure 6: Two-Stage PRV



## ABOUT US

Inveno personnel are experts in the field of steam and condensate systems engineering with vast real-world experience and highly recognized professionals in the industrial arena. Our services include design, engineering, requests for quotations, standard operating procedures, root cause analysis, system optimization, steam balancing and project management. Inveno can review your entire steam and condensate system from steam generation to distribution to end user processes and condensate recovery.